

Syracuse Thunderbirds Aero Radio Society

Plane Propwash

May 2012

Charter 473

The General Meeting will be June 13th at 7:00 at the STARS Field

2012 Officers

Chuck LeVine, President
Phil Morgan, Vice President
Bob Rowe, Treasurer
Jeff Wolsley, Secretary
Peter Seiffert, Safety Officer

Directors:
Roy Fields, 2010
Peter Seiffert, 2007-08
Scott Erich, 2006

Volunteer Staff:
Jeff Wolsley, Propwash Editor
Michael Graham, SYG Administrator
Chuck LeVine, Webmaster
Herb Moore, Field Committee

The next STARS meeting will be June 13th, at 7:00. As a reminder, the meeting is always the second Wednesday of the month.

Heli-Jam June 30th!

President's Perspective

We are off to a moderately slow start to our flying season - both flight schools have been reasonably well attended for all of the foul weather we have been having. The field committee has done an outstanding job of keeping the field looking great despite the adverse weather. We can always use more volunteer instructors, so please feel free to join the fun at our fixed wing flight school.

Next up is the 4th Annual Heli-Jam on June 30th - sponsored by Walt's Hobby. We will have raffles and food available. Art Hughes,

who is sponsored by HeliWholesaler/ Miniature Aircraft - Byron Fuel - Futaba - Thunder Power - Castle - SwitchGlo, will be at the event to do some amazing demo's and available for information and setup. Also please take a minute and stop in at Walt's Hobby and thank Bruce for all of the terrific support he provides to our club. We can always use an extra hand or so at this event, so please come out and see some really great flying and help us make this a great event.

Hope to see you all out flying.....

Chuck



The Prugger Memorial Bench is now in the clubhouse. This beautiful bench was donated by the Prugger family as a way to remember Bob. Please do not take the bench outside. It will not take the weather well.

Secretary's Report:

The May 2012 STARS regular meeting was called to order at 6:57pm. There were 11 Full members, 4 Associate member, 0 youth members, and 1 guest in attendance.

Secretary's Report: The Secretary's Report from the April meeting was submitted. Peter asked to change the time of the MoST date from 140:30 to 10:30. Thanks Peter. Motion to approve by Peter Seiffert and 2nd by Mike Graham. Carried.

Treasurer's Report: Bob Rowe

Treasurer's Report from the April meeting was submitted. There is still one open member unpaid. The Port-a-Potty for 2012 has been delivered and first installment paid. Motion to approve by Dave Jewell and 2nd by Mike Graham. Carried.

Committee Reports:

Field Committee: Herb Moore

No field report recorded for the May meeting.

AMA: Peter Seiffert, AMA District II, AVP

Peter reported the FAA NPRM has been moved to July. We still need to be vigilant in our efforts to protect aeromodeling despite the recent bill that was passed. Please use the Government Relations button on the AMA website to contact our representatives in the event the NPRM contains any rules that will impede our ability to enjoy our hobby.

The MoST program is concluding with the Team Rocket Challenge on June 2nd. Bruce Throne will fly a heli demo at the event. There will be 200 balsa gliders and Park Pilot magazines given away.

Safety Report: Peter Seiffert

No safety report for the May meeting.

Flight School: Bob Rowe

The heli school is off and running. There were approximately 6 pilots at the first meet.

Fixed wing starts tomorrow.

Volunteer pilot instructors are needed 4 to 6 for both schools.

Jim Coleman is cooking again for the schools.

STARS Web Site: Chuck LeVine

Please check out the STARS site. The webcam is up and running- <http://www.amadistrictiistars.org/>
<http://www.amadistrictiistars.org/webcam.html>

Long Range Planning:

The propane tank has been installed. It will be reinstalled in the correct location shortly.

Old Business:

Dave Jewell has volunteered to collect and return the bottles and cans collected at the field. The deposit money will be returned to the STARS Treasury.

Heli Jam:

The event is on for June 30th. Volunteers are needed for the event. Please see/contact Chuck LeVine for an event assignment.

STARS Hats: Bob Rowe

Bob has more hats! The price is \$ 15.00

Club Shirts: Bob Rowe

Please see/contact Bob if you are interested in a STARS shirt. These are available in a couple of styles with the STARS logo embroidered on it. The price varies from 10.00-40.00 dollars. These are **nice** shirts.

New Business:

Bob Russell has been battling recent health issues. Bob is selling off much of his collection. Bob is having a sale May 26th 10-3:00

There will be a swap meet on May 19th at Redneck's. Many of the items there are from Larry Carlson's collection.

New Members:

Mark Koster from Oswego has been confirmed as an Associate member. Mark is sponsored by Herb Moore. Motion to accept by Dave Jewell and 2nd by Bill Orr.

Adjournment:

The May regular monthly meeting of the STARS was adjourned at 7:17 pm.

Secretary, Jeff Wolsley

Safety Officer Report: Peter Seiffert

NEWS BLAST for all gasoline engine users. The Fastrac gas station at Rt. 57 and Rt. 31 is advertising premium no ethanol gasoline. As am sure all gasoline engine users know the ethanol is very hard on all the rubber carburetor parts.

This is an arming circuit sketch for either parallel or series wired circuits. These are the most common ways that you may have wired your electric aircraft. There are also different variations depending on weather or not you use a BEC (Battery Eliminator Circuit) to power the onboard receiver and servos or have two or more motors.

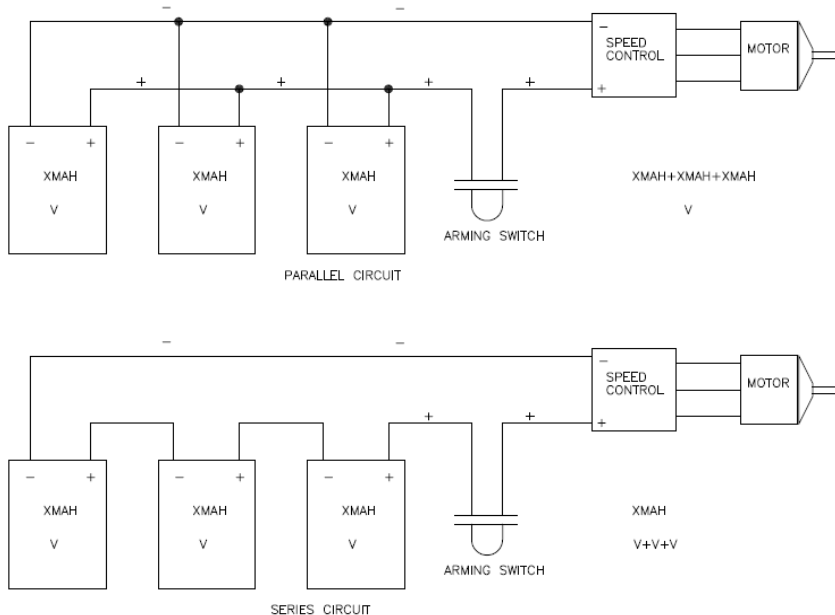

100amp= 10ga wire
80amp= 12ga wire
50amp= 14ga wire

Arming plugs are commercially available, or it is possible to make your own. Dean's plugs or Anderson Power Pole (APP) plugs are good choices. The APP's are available now in several different sizes for different amperage requirements. APP also makes shunt plugs that can be used as arming switches for higher amperages.

Safety is everyone's concern!
Peter Seiffert, Safety Officer

Calendar of Events for May-July (and beyond) Events: *Editor's Note- Also watch your e-mail for sudden changes to events like cancellations or re-scheduling due to weather.*

May 5 Swap Meet Watervliet Wind Warriors
4th Annual Watervliet "Dome"

May 19 Redneck RC Swap Meet

May 20 Seaway Valley Modelaires Massena, N.Y.

Mat 26 Bob Russell sale

June 2 Team Rocket Launch Challenge

June 21-24 IMAA Giant Scale IMAA Rally Chenango Bridge Airport Chenango Bridge, N.Y.

July 21-22 Sayre Valley RC Fun Fly- Sayre, PA.

June 30 STARS Heli JAM

July 28 Mountain R/C Modelers Annual Fly In- Old Forge, NY.

Look for updates to indoor flying schedules!

Indoor helicopter flying at Walt's is open again for the 2011-2012 season. Wednesday and Thursday, 5:30 to close.

For any additional information contact Walt's Hobby 453-2291

Flight Schools- 2012 STARS Flight Schools start on April 24 with the Helicopter Flight School. Pre-Flight fixed wing check is April 26 at Walt's

MOST Volunteer Schedule- Please contact Peter Seiffert to volunteer. The MoST program is up and running. Next date is May 5th.

Please visit the AMA DistrictIII website or the Event Section in the back of Model Aviation for additional information on these and other events.

Advertisements:

FOR SALE:

Blade SR helicopter with 3 batteries for \$250.00. Contact Brian Maestri 315-391-3675 p.maestri@gmail.com

If you want to list modeling items for sale, R/C services offered, or a really neat R/C web site, this would be a good spot. Free for members. Send your advertisement by e-mail to jwolsley@ix.netcom.com. Please put STARS ADVERTISEMENT in the subject line.

how to build a rc jet B-1 Bomber # 173 pt 1

hornitpilot 404 videos  Edit Subscription



This is the link to the web site- <http://www.b1modelproject.com/>

Links-

A REALLY COOL WEBSITE- Thanks to Rick Colvin for pointing this out at the June 2009 meeting- For those of you who ever wanted to learn how to make a fiberglass plug and molds, this is the guy to check out. Even if the plane in the project doesn't interest you, the education from the process may. Bob Moore (B1 Bob) takes you through each process step by step. If the YouTube hyperlink doesn't work, copy the following URL into your browser line and click go. It's up to almost 2000 videos now. Bob is completing 10 kits for his successfully flown and now proven F-105 on spec to help fund the B-1 project. Five kits have been sold. Bob recently sold a 2nd ready to fly Thud. The original B-1 is for sale on RC Universe. Bob will be starting on the improved B-1 shortly. How To Build A B-1 Bomber 10 Minutes At a Time http://www.youtube.com/watch?v=HqTKJU6PlkA&feature=channel_page

Tom Catalino pointed out this site recently. An excellent site for Lipo battery info- <http://sites.google.com/site/tjnguytech/charging-how-tos/balance-connectors>

Peter Seiffert sent along the following web site- www.servodatabase.com/servos/all

Mike Graham has a torque conversion chart-



Arming Switch Information-

AMP'D- Arming The Big Boys, by Greg Covey November 2007
http://www.rcuniverse.com/magazine/article_display.cfm?article_id=950

RunRyder- How To Make A Spark Arrestor for an ESC by Lucien Miller <http://www.helifreak.com/archive/index.php/t-289393.html>
look down to the post from gbidwell from 4-24-2011 0601am. That's the exact article that I have from RunRyder.
Note- Many of the newer ESC's have a built in spark arrestor. If you still see and hear the spark, this is a good idea to save the plugs.

The Link for the AMA is:

<http://www.modelaircraft.org/>

The link for the AMA DII Calendar is:

http://www.amadistrictii.org/amajoom/index.php?option=com_events&Itemid=56&task=view_month&month=6&year=2012

The link for the club yahoo users group is:

http://groups.yahoo.com/grjwoup/stars_club_members/ (Don't forget to sign in)

The link for the STARS club home page at DII is

<http://www.amadistrictiistars.org/>

The link for the STARS club web cam is:

<http://www.amadistrictiistars.org/webcam.html>

The Propwash News Letter is also available at YAHOO GROUPS. The current news letter and previous years/months are viewable and printable from there.

Please contact Mike Graham tanjmg82@aol.com to join the STARS Yahoo group. Send Mike an email asking to join from your preferred email account. Mike will then reply with an invite to join the group. The invitation contains the links and instructions necessary to join.



STARS Field Satellite photo

S.T.A.R.S.

Flight Training Program



2012



When?

Every Thursday evening from 5:30 PM to Sunset
May 10, 2012 through September 13, 2012

Where?

At the S.T.A.R.S. field in Phoenix, New York
649 County Route 12, Pennellville, NY 13132
N43.23696, W76.24550

Who?

Anyone wanting to learn to fly powered R/C model airplanes!! You do not have to be a Club member and all lessons are free. Each student must furnish his/her own plane and radio equipment and also must hold a current membership in the Academy of Model Aeronautics aircraft association in order to fly.

PreFlight Workshop

Held at Walt's Hobby
Thursday April 26, 2012 at 7 PM

Interested?

Contact:

SENIOR FLIGHT INSTRUCTOR: Bob Rowe (474-8428)



Syracuse Thunderbirds Aero Radio Society

Phoenix, NY

Charter 473

2012 Helicopter Flight School

*All skill levels welcome but must be a current AMA
Member and provide your own outdoor Helicopter*

**Tuesday evenings – April 24 to October 9
5:00 pm until dusk**

CNY Heli Jam



Hosted by: S.T.A.R.S.
and Syracuse Heli Group



PILOT REGISTRATION FORM

R/C Helicopter Fun Fly

June 30, 2012 10AM –Until ?

S.T.A.R.S. Field 649 County Route 12, Pennellville, NY 13132

Pilot Name: _____

Address: _____

AMA #: _____

E-Mail: _____ Phone: _____

Pre Registration Fee \$10.00 due by 6/9/12 (This is to reserve a shirt)

Registration at field: \$15.00

Official T Shirt : ___ LG, ___ XL, ___ XXL, ___ 3XL (One per pilot)

Total: _____ Make check or money order payable to S.T.A.R.S.. *Please don't send cash! Please print this form and mail check or money order to:*

S.T.A.R.S.
c/o Chuck LeVine
785 Fyler Rd. Lot 50
Kirkville, NY 13082

Will you need an overnight camping space? We have space for a few, **NO HOOKUPS** . Let us know.

S.T.A.R.S.
c/o Chuck LeVine
785 Fyler Rd. Lot 50
Kirkville, NY 13082

N43.23696, W76.24550

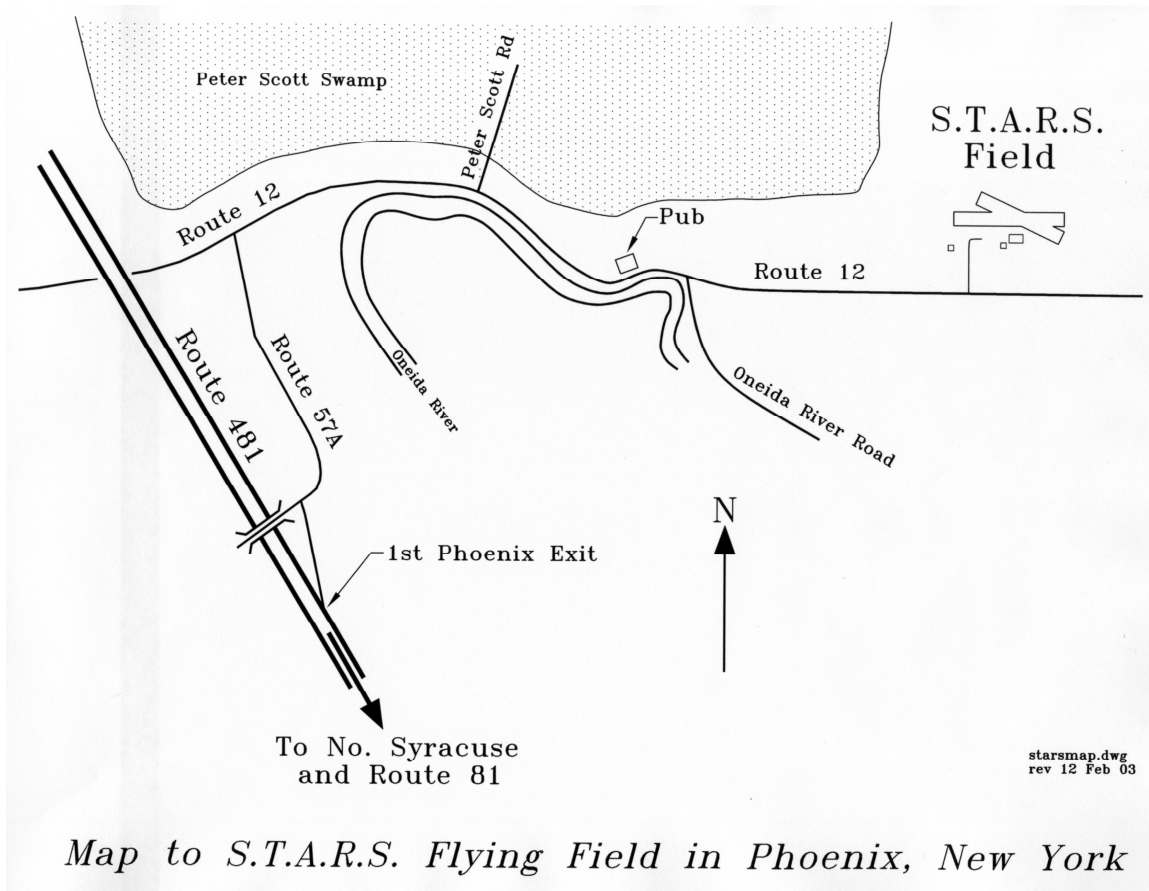

Map to S.T.A.R.S. Flying Field in Phoenix, New York

Hotels Nearby:

(These are located approx 2 miles south of the field at Rte 31 and Rte 481)

Fairfield Inn

3979 State Route 31, Liverpool, NY

315-622-2576

Hampton Inn Syracuse Clay

3948 State Route 31, Liverpool, NY

[Website](#) | 315-622-3443

SPRING COMPETITION FOR MIDDLE AND HIGH SCHOOL STUDENTS



ORGANIZED BY Milton J. Rubenstein **Museum of Science & Technology**
with the **LC Smith College of Engineering and Computer Science** at Syracuse University

DATES **Informational Meeting and Materials Pick-Up**
Thursday, April 26, 3:30 – 5 PM
Thursday, May 3, 3:30 – 5 PM
Launch
Saturday, June 2 at 9 AM

TWO DIVISIONS **Middle School** (4th through 8th grades) and **High School** (9th through 12th grades)
School teams should consist of four to five students.

Sign up to design, build and fly a high-power rocket. Your school will receive materials, rocket simulation software and training to build a rocket capable of lifting an electronic payload with “eggstronaut” to peak altitudes between 200 and 400 meters. A general informational meeting in April will take place at the MOST, where we will distribute materials to school teams and associated school instructors. Each rocket will carry a video and audio acquisition device with real time transmission back to the launch site, and a high speed digital altitude recorder.

The school teams design and build their rockets to be ready for flight on Saturday, June 4 at the Syracuse University Skytop launch site.

CRITERIA **Competition and judging of the rocket teams include:**

- 1 Aesthetic look of the rocket,
- 2 Student presentation, which incorporates relevant technical knowledge,
- 3 A successful flight,
- 4 Successful “eggstronaut” payload recovery, and
- 5 Precision in estimating the apogee of your rocket.

College faculty and professional engineers will judge and present awards to the winning teams. All team members will receive certificates of participation and the three top teams in each of the two divisions will receive school plaques.

Participants in the CNY Rocket Team Challenge will experience team work and computer design; learn the fundamentals of rocket science with components of electrical, mechanical and chemical engineering; and experience the thrill and exhilaration of high power rocketry!

TO REGISTER www.most.org/rockets

CONTACT **Peter Plumley**, MOST, rocket@most.org or **315.425.9068** x2163

MAJOR SPONSORS **Lockheed Martin Corporation** • **TACNY** • **NASA New York Space Grant**



40th Annual AMA Sanctioned

FUN FLY CONTEST

Sat. & Sun. JULY 21-22, 2012



*9am to 4 pm
VRMC FIELD
ROUND TOP PARK
off RT. 220, Athens, Pa.*



Expert-Sportsman-Junior Classes

Point & Timed Events

AMA (or MAAC) Required

Trophy & Merchandise Awards

Free Camping (no hook-ups) - Saturday Picnic Supper

***HELP US CELEBRATE 40 YEARS OF
FUN FLY CONTESTS !***

For information – contact
Valley R/C Model Club – CD–Jim Champion
2850 Orange Hill Rd - Athens, PA 18810
ph (607) 742-9779
email jim.champion@lmco.com



WWW.VALLEYRCPA.COM



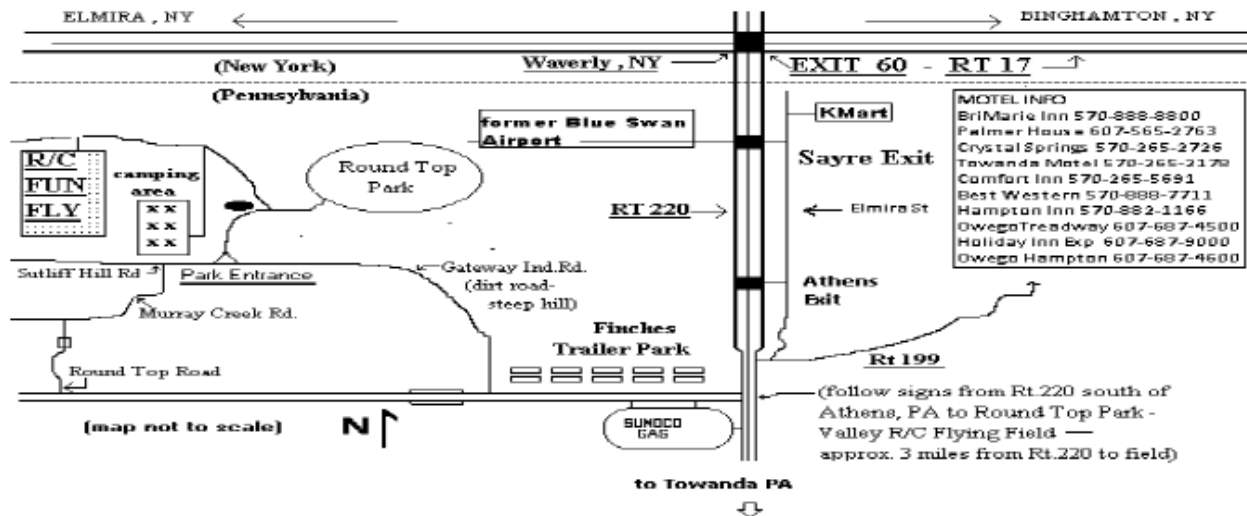

VALLEY R/C FUN FLY INFO

Entry Fee - \$30 – Junior \$20 (entry includes 1 picnic meal)

Events announced day of contest – a mixture of point and timed Fun Fly Events. Overall awards by Class based on event placement points.

3 Classes of Fun Fly Events

***EXPERT FUN FLY** – No plane/pilot restrictions except no stick/boom aircraft allowed.

***SPORTSMAN FUN FLY** –No mixing, no stick/boom aircraft.

***JUNIOR FUN FLY** –(same as Sportsman) + pilot age 16 or less

(profile planes allowed in all classes per AMA Rule 705 specs)

Open Flying between rounds of competition for any size/type plane or helicopter. May be some special events !

WWW.VALLEYRCPA.COM

**MOUNTAIN R/C MODELERS
OF OLD FORGE, NEW YORK**

AMA Charter 3688



Presents the 11th Annual

Fly-In and Fun-Fly!!

Saturday July 28, 2012 9am-4pm

Air Show at 1pm

At the airfield, the end of North Street (Turn by Subway and the Pied Piper)

1000' grass facility.

AMA membership
required to fly.

**All Are Welcome!
Food and Soda are Available!**

**Come enjoy the central
Scenic Adirondack Mountains!**

Area Motels:

Water's Edge Inn	315-369-2484
Pine Knoll Motel	315-369-6740
Best Western Sunset Inn	315-369-6836

Camping Available at:

Old Forge Camping Resort	315-369-6011
Nick's Lake State Campground	315-369-3314

Also See:

oldforgeny.com for more information on facilities,
or, call the Visitors Information Center at
315-369-6983

Contest Director: Walt Throne 315-559-8826



NYS Thruway I-90 Exit 31 Utica Rt 12 North, Rt 28 North 1 hour to Old Forge. 2 Hours from Syracuse; 2 1/2 hours Albany!
Rt 28 from I-87 Northway (Warrensburg): Rt. 28 from Rt 12 Lowville/Watertown



Est. 1965

Syracuse Thunderbirds Aero Radio Society

Online at: <http://www.amadistrictiistars.org>



Charter 473

Membership Application Form

Date: _____

Membership: Open (\$220.00 share+dues) Extra Family member (\$30.00)
 Associate (\$75.00) Youth (< AMA age 19 - \$5.00)
 Park Pilot - Associate (\$75.00) Park Pilot - Youth (< AMA age 19 - \$5.00)

Name: _____

Address: _____

Phone: _____

AMA: _____ DOB: _____

RC Channels Used: _____

STARS Member(s) Contacted: _____

Primary Interests (Sport, Scale, Pattern, Fun Fly, etc.): _____

Other Club Affiliations: _____

Desired Name on Nametag: _____

Email Address (for newsletter and notices): _____

You must be a current member of the Academy of Model Aeronautics (AMA) in order to join the STARS. Please show your AMA card to the Officer given this application or include a photocopy of the application for the license.

"I have read and agree to abide by the STARS Field Safety Rules." (on back)

Submit this form to a Club Officer

Rev 04/10/09

STARS CLUB RULES

1. General:

A. License: All pilots, students, and flying guests *must* have a current membership in a nationally recognized model aircraft association in order to fly.

B. Spectators: Only those people essential to flight operations will be permitted in the pit area; all others will remain on the spectator side of the fence.

C. Impound: All pilots, students, and flying guests must place their transmitter(s) in the impound area immediately upon arriving at the field.

D. Vehicles: Vehicles will not be permitted *on* the flying field.

E. Crash Debris: Pilots must retrieve all pieces of their aircraft after a crash. Particularly, attention must be made to obtaining all pieces of aircraft that land in the neighboring fields under cultivation.

F. Trash: All members will take home their own trash.

G. Alcoholic Beverages: Members will not consume alcoholic beverages prior to, nor during, participation in any *modeling* operations.

H. Smoking: Smoking will not be permitted in the pit area or on the flight line.

I. Mowing: Flying on the field will not be permitted if the field is being mowed or maintained.

J. PPMP: Those pilots participating in the Park Pilot Membership Program must fly models that weigh two pounds or less and be incapable of reaching speeds greater than 60 mph. They must be electric or rubber powered, or of any similar *quiet* means of propulsion.

2. Transmitters:

A. Frequency Control (*For non 2.4 GHz transmitters only*): All members, students, and guests *must make use of the field frequency control system*. Each pilot will obtain the correct frequency flag (or pin) from the impound board and attach it to his/her transmitter before attempting to fly.

B. Range Checks: Each pilot will conduct a successful radio equipment ground range check before flying a new or repaired aircraft and prior to each flying session .

3. Engines:

A. All internal combustion engines run at the field will have a silencer (except for small displacements of .09 cubic inches or less).

B. When running an engine in the pits, keep neighboring personnel behind the prop arc.

4. Flying:

A. Boundaries: Flying over the pit area or the spectator side of the fence is prohibited, unless beyond the control of the pilot(s).

B. Taxing: Taxing is prohibited in the pit area!

C. Flying:

(1). Pilots will initiate their first turn after takeoff away from the pit and spectator areas.

(2). Engines will not be started before 9 AM Monday through Saturday and 11 AM on Sunday, unless approved by the Event Director.

(3). No more than three aircraft will be permitted in the air at one time.

(4). All flying will be conducted from the designated flight boxes.

(5). Hand launching of aircraft is prohibited from the pits.

(6). Flight operations will cease during electrical storms.

5. Guests:

A. All guests must have a current membership in a nationally recognized model aircraft association in order to fly.

B. Guests may fly at the field only with the approval of a member in good standing and only as long as a sponsoring member *remains at the field*. Guests will not fly unattended.

C. A local guest will be allowed to fly at the field on three (3) separate occasions and then will be asked to join the Club.

D. An out-of-town guest may make arrangements with the Club to fly at the field while visiting the area. The Club Officers and the Safety Officer will handle each out-of-town visitor on a case-by-case basis.

E. *All guests are required to extend every courtesy to current members sharing the same flying frequency*. But when there is a conflict over who shall fly, the Club member will have the first option to fly. Both the guest and the members should use common sense while sharing the flight line or using the same radio frequencies.

Plane Propwash

Syracuse Thunderbirds Aero Radio Society
Monthly News Letter
May 2012